

MODULES & RECEIVERS FOR ANALYTICAL & MOLECULAR APPLICATIONS



Single Photon Counting Modules – SPCM

Applications

- Particle sizing
- Confocal microscopy
- Photon correlation spectroscopy
- Quantum cryptography
- Astronomical observation
- Optical range finding
- Adaptive optics
- Ultra sensitive fluorescence

Features and Benefits

- Peak photon detection efficiency at 650 nm: 65 % typical
- Active area: 180 μm diameter
- Gated output
- Single +5V supply
- FC receptacle option for fiber coupling
- EU RoHS compliant
- Array of 4 channels available

Product Description

SPCM-AQRH is a self-contained module that detects single photons of light over the 400 nm to 1060 nm wavelength range - a range and sensitivity that often outperforms a photomultiplier tube. The SPCM-AQRH uses a unique silicon avalanche photodiode (SLiK®) with a circular active area that achieves a peak photon detection efficiency of more than 65 % at 650 nm over a 180 μm diameter. The photodiode is both thermoelectrically cooled and temperature controlled, ensuring stabilized performance despite ambient temperature changes. Circuit improvements have reduced the overall power consumption.

Count speeds exceeding 20 million counts per second (Mc/s) are achieved by the SPCM-AQRH-1X module (> 30 million counts per second on some models). There is a “dead time” of 35 ns between pulses but other values can be set at the factory.

As each photon is detected, a TTL pulse of 2.5 Volts (minimum) high into a 50 Ohm load and 15 ns wide is output at the rear BNC connector. The module is designed to give a linear performance at a case temperature between 5° C and 40° C.

The SPCM is also available in a 4 channel array format, the SPCM-AQ4C. It is a module of 4 APDs with single power supply and 4 individual outputs.

This series of photon counting modules are designed and built to be fully compliant with the European Union Directive 2002/95/EEC - Restriction of the use of certain Hazardous Substances in electrical and electronic equipment (RoHS).

Graph 1

Characteristics SPCM Series

Photon Detection Efficiency (Pd)

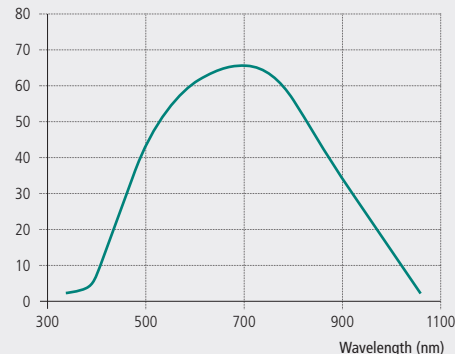

Product Table

Single Photon Counting Modules – SPCM

Part Number	Photo Sensitive Diameter	Maximum Dark Count Rate	Photon Detection Efficiency @ 700 nm	Max. Count Rate before Saturation	Dead Time	Pulse Width
Unit	mm	c/s	%	c/s	ns	ns
SPCM-AQRH-10	0.18	1500	65 %	25M	32	15
SPCM-AQRH-11	0.18	1000	65 %	25M	32	15
SPCM-AQRH-12	0.18	500	65 %	25M	32	15
SPCM-AQRH-13	0.18	250	65 %	25M	32	15
SPCM-AQRH-14	0.18	100	65 %	25M	32	15
SPCM-AQRH-15	0.18	50	65 %	25M	32	15
SPCM-AQRH-16	0.18	25	65 %	25M	32	15
SPCM-AQ4C	Fibered	500	60 %	>2M / channel	50	30
C30902SH-TC ¹	0.475	2500	>5 %	-	-	-
C30902SH-DTC ²	0.475	350	>5 %	-	-	-

1. C30902SH-TC (0° C operation), 2. C30902SH-DTC (-20° C operation)

Figure 1

Mechanical Dimensions of the SPCM-AQRH Series

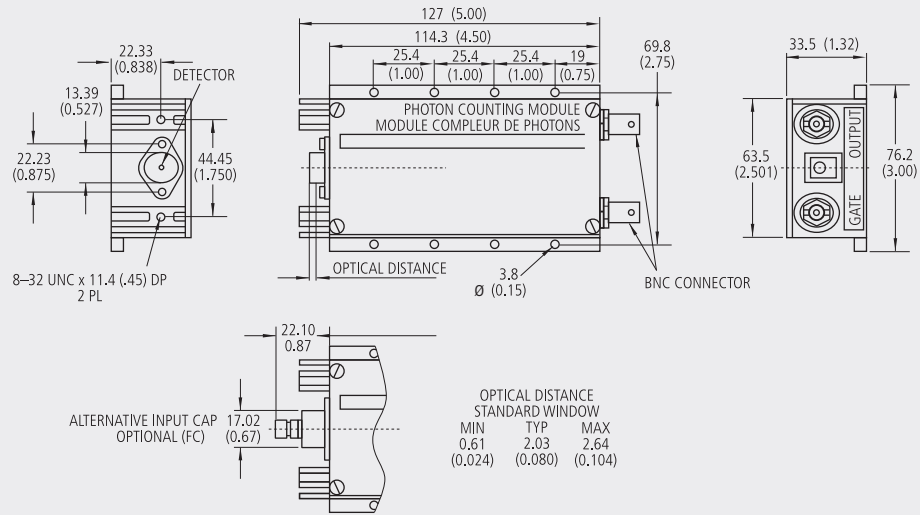

Figure 2

Mechanical Dimensions of the SPCM-AQ4C

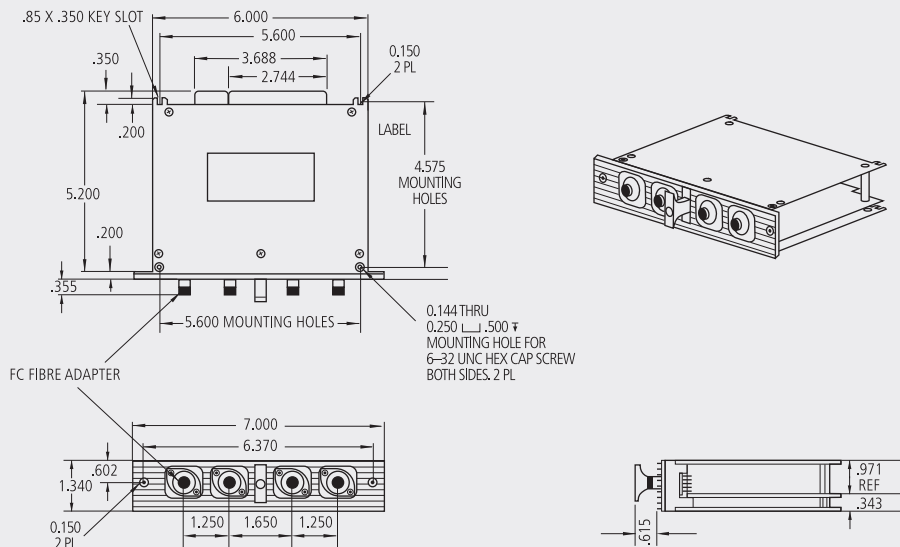

Figure 3

Package Drawing – TO-8 Flange

